

Complete Unit

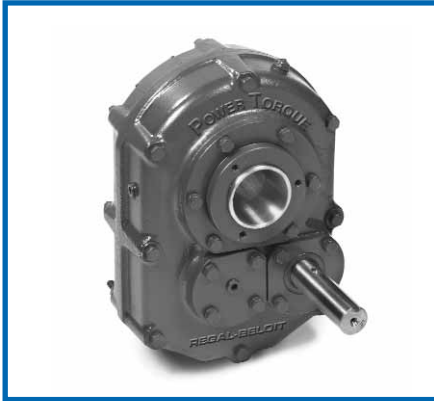

Standard Accessories



Screw Conveyor Accessories



FOOTE-JONES

POWER TORQUE® Shaft Mount Reducers

FEATURES	G2 - G3
NOMENCLATURE	G4
HOW TO ORDER	G5
SELECTION INSTRUCTIONS	G6 - G7
MECHANICAL RATINGS	G8 - G9
SELECTION BY HORSEPOWER	G10 - G14
SHAFT MOUNT REDUCER DIMENSIONS	G15
SCREW CONVEYOR ACCESSORIES	G16
TAPERED BUSHING & BACKSTOP KITS	G17
VERTICAL MOTOR MOUNTS	G18 - G19
HORIZONTAL MOTOR MOUNTS	G20 - G21
BELT GUARDS	G22 - G23

See Section H
For 8000 Series
Heavy-Duty Shaft
Mount Reducers

G2 The FOOTE-JONES Advantage

The FOOTE-JONES PowerTorque® Shaft Mount Reducers are manufactured to the highest quality standards in the industry. Assembled using precision manufactured components made from top quality materials, the PowerTorque® assures dependable longevity while providing trouble free service. Backed by an 18 month warranty, the FOOTE-JONES PowerTorque® is designed for the toughest applications in the industry.

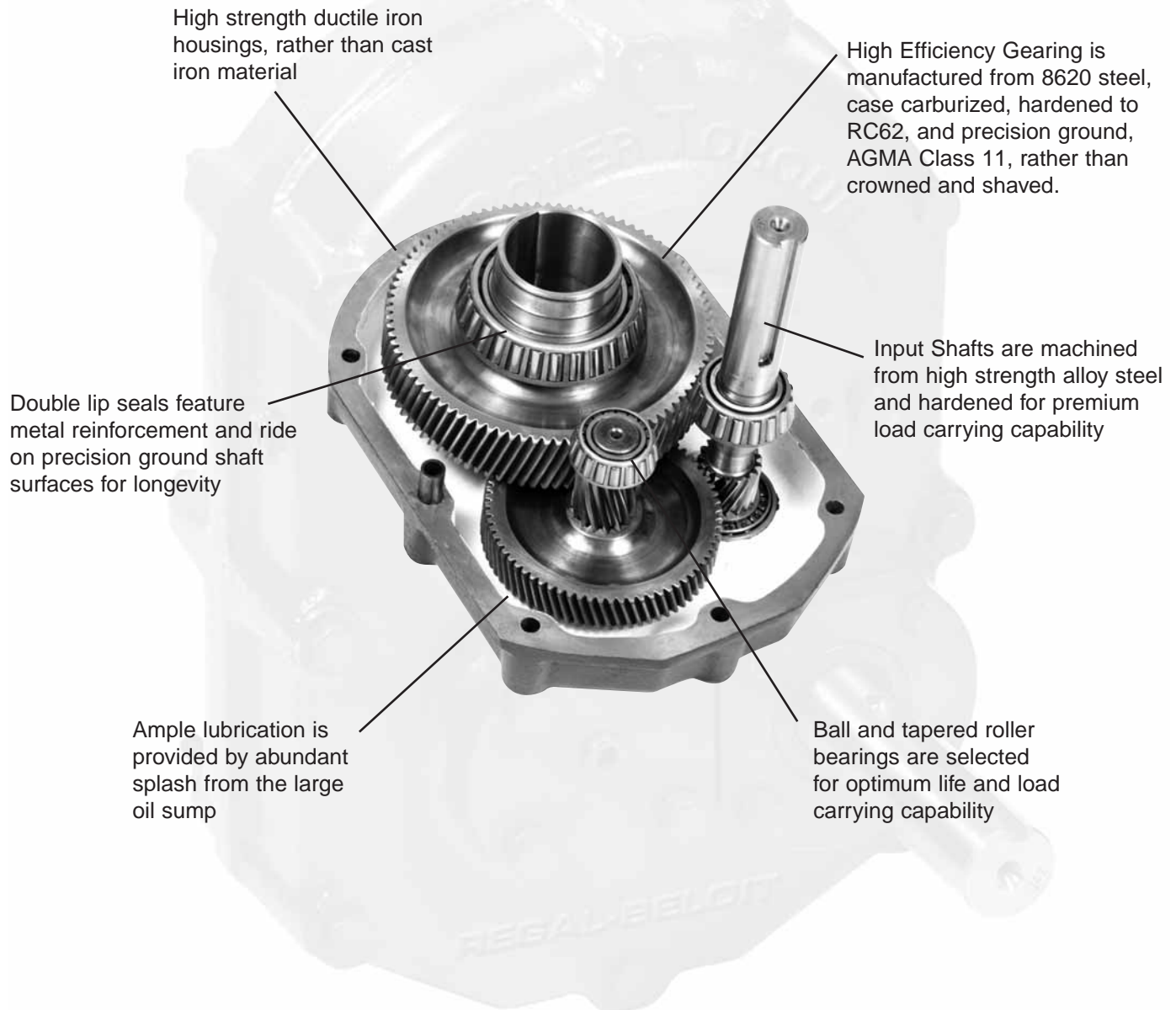

Eight models available from 1/4HP through 125HP capacity. Standard bores range from 1-1/4" through 4-7/16". Three ratios: 9:1, 15:1 and 25:1 complete the drive offering. Dimensionally and mechanically interchangeable with most major brands.

The FOOTE JONES Advantage G3

FOOTE-JONES PowerTorque® Accessories complete the drive package by providing tapered bushings, backstops, motor mounts and belt guards. Screw conveyor drive accessories include adapter flanges and drive shafts.

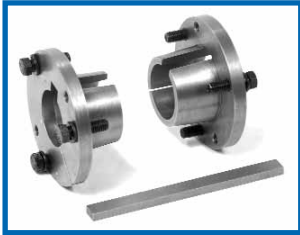

Flanged bushing mount
Removal screws allow for easy demounting
Ductile Iron material for shock resistance
Clamp fit, no setscrews
Split design eliminates seizing problems

TAPERED BUSHING KITS



Quick installation on input shaft
Internally installed, sealed from contamination
Lubricated by internal gear lubricant
Designed to operate in either direction

BACKSTOP ASSEMBLIES

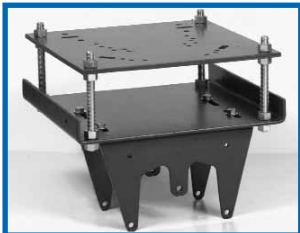

All-Steel construction for rigidity
Compact design eliminates need for motor base
Top plate adjusts for easy tensioning of drive belt
Mounting holes provided match NEMA standards

MOTOR MOUNTS



Conform to CEMA standards
Bolt-on design allows easy mounting
Open center for contaminate dropout

SCREW CONVEYOR ADAPTER FLANGES



Machined from high strength alloy steel
Conform to CEMA dimensional standards
Easy installation into standard hollow bore

SCREW CONVEYOR DRIVE SHAFTS



All-Steel construction
Adjustable to fit a wide range of sheaves and motor frames
Designed for easy installation, no drilling required

BELT GUARDS



G4 Descriptions For Ordering Shaft Mount Reducers

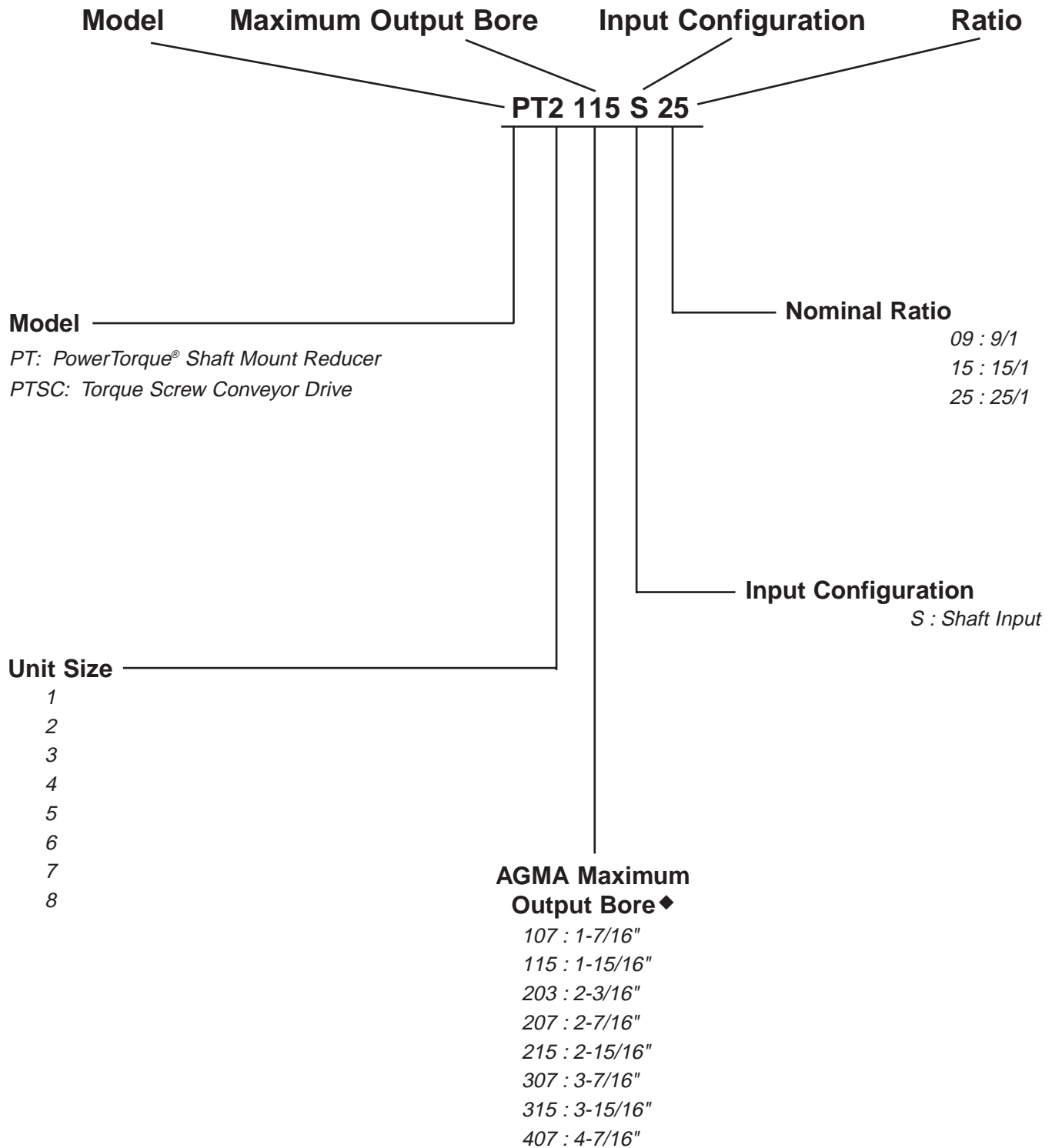

♦ Refer to page G17 for optional tapered bushing bore sizes.

HOW TO ORDER

The following examples are presented to assist you in ordering the PowerTorque® product. All required unit and accessory designations and descriptions should be included with each purchase order placed with FOOTE-JONES.

Nomenclature

PT	PowerTorque® reducer
PTSC	PowerTorque® screw conveyor
S	Shaft input configuration
BK	Backstop kit
VM	Standard vertical motor mount*
VLM	Vertical long motor mount*
HM	Standard horizontal motor mount*
HLM	Horizontal long motor mount*
BG	Belt guard

Example #1

PT3202S25 – Standard PowerTorque® size 3 reducer with standard 2 3/16" maximum bore and 25:1 ratio.

Example #2

PT4207S15-2 1/4 – PowerTorque® size 4 reducer, 15:1 ratio and 2 1/4" bushing kit. Please refer to page G17 for listing of available bushing kits.

Example #3

PTSC2115S15-1 1/2 – PowerTorque® screw conveyor drive, size 2, 25:1 ratio and 1 1/2" drive shaft diameter. Please refer to page G16 for listing of available drive shaft diameters.

Example #4

PT6307S9-2 7/8-BK – PowerTorque® size 6 reducer, 9:1 ratio, 2 7/8" tapered bushing kit and a backstop kit. Please refer to page G17 for optional backstop kits.

Example #5

PT5215S25-2 1/2-VM-BG – PowerTorque® size 5 reducer, 25:1 ratio, 2 1/2" tapered bushing kit, standard vertical motor mount and belt guard. Please refer to pages 20-23 for optional mount motors and pages G22-G23 for optional belt guards.

*Include motor frame size on all purchase orders. Refer to pages G18-G21 for availability.

G6 Selection Procedure

FOOTE-JONES PowerTorque® reducers are selected on the basis of input horsepower and output speed. There are eight double reduction PowerTorque® Models available in nominal ratios of 9:1, 15:1, and 25:1 with output speeds to 200 RPM and ratings up to 125 HP. The selection tables have been established so that once the horsepower and driven speed are known the appropriate model can be readily selected.

AGMA LOAD CLASSIFICATION NUMBERS

Determine the AGMA Load Classification Number for your application from section J. In mechanical drives the presence of shock loads will usually reduce the life of the reducers. In order to provide optimum service in heavily loaded applications, it is necessary to use load classes to adjust the reducer ratings for the stresses created by different types of loads. The AGMA Load Classes provide for a momentary or starting load of 2.0 times for Class I, 2.8 for Class II, and 4.0 for Class III. Refer to section J for further info and cautions on the selection of proper service factors.

Load Class (S.F.)	Up to 3 hrs. total operation per Day	3 to 10 hrs. total operation per Day	Over 10 hrs. total operation per Day
I (1.0)	Moderate Shock Load	Uniform Load	
II (1.4)	Heavy Shock Load	Moderate Shock Load	Uniform Load
III (2.0)		Heavy Shock Load	Moderate Shock Load

SELECT REDUCER SIZE AND RATIO

Refer to the applicable Selection Table for the AGMA Load Class I, II, or III on pages G10 to G14. Locate the required HP and Output Speed, and read across to find the reducer size.

SELECT TAPERED BUSHINGS

Compare the hollow shaft bore with the diameter of the driven shaft. If the driven shaft is smaller than the maximum bore for the reducer selected, select the proper tapered bushings from the table on page 19 to adapt the hollow shaft bore to the diameter of the driven shaft. If the driven shaft diameter is larger than the maximum bore for the reducer selected, it is necessary to either turn down the driven shaft, or select a larger reducer.

SELECT SHEAVE RATIO

To determine the V-belt sheave ratio required to produce the desired output speed, use the following formula: sheave ratio = exact motor RPM / (output RPM X exact gear ratio). Refer to the catalog of your chosen V-belt supplier to select the most economical V-belt drive to transmit the HP at the required output speed by following the selection procedure outlined in the V-belt catalog.

CAUTION

Refer to the Minimum Diameter for Driven Sheaves listed in the Selection Tables to be certain that your driven sheave selection is larger than the minimum diameter recommended for the reducer selected.

ACCESSORIES**Select Screw Conveyor Drive Shaft and Adapter**

Select the CEMA adapter and drive shaft from the tables on page G16 based on the reducer size.

Select Motor Mount

Select the motor frame and motor mount size from the tables on pages G19 and G21 based on the reducer size.

Select Belt Guards

Select belt guards from the tables on pages G22 and G23 based on the reducer size.

Select Backstop

Optional backstops are available for applications that require the prevention of reverse rotation. Select the backstop from the table on page G17 based on the reducer size. Backstops are installed on the high speed pinion shaft by removing the cover on the back side (opposite side from the input shaft extension) of the housing.

CAUTION

Backstops are not recommended for applications involving energy absorption and shock or torque loads in excess of reducer ratings or on applications such as chair lifts, amusement rides, etc. where the safety of a person or property is dependent on their function. On such applications, other safety devices should be provided.

Backstops are designed to prevent rotation not more than five times in an 8 hour period with a minimum of one minute in the over-running direction between each engagement. If reversing operation is more frequent or over-running time is less, the application should be referred to the factory.

CAUTION

Lubricants with extreme pressure (EP) additives should not be used in units with backstops installed.

Other Accessories Supplied Upon Request:

Cooling Fans
Mounting Brackets
Auxiliary Seal Kits

Note: A torque-arm assembly is supplied with all shaft mount reducers.

G8 Mechanical Ratings

INPUT HORSEPOWER AND OUTPUT TORQUE, 1.00 SERVICE FACTOR

9/1 Nominal Ratio

OUTPUT RPM	PT1107		PT2115		PT3203		PT4207	
	Actual Ratio 9.23/1		Actual Ratio 9.05:1		Actual Ratio 8.98:1		Actual Ratio 8.80:1	
	INPUT HP	OUTPUT TORQUE (IN-LB)	INPUT HP	OUTPUT TORQUE (IN-LB)	INPUT HP	OUTPUT TORQUE (IN-LB)	INPUT HP	OUTPUT TORQUE (IN-LB)
200	9.1	2753	11.6	3494	30.1	9118	45.0	13598
190	8.8	2802	11.0	3503	28.7	9133	42.7	13604
180	8.5	2857	10.4	3503	27.2	9150	40.6	13630
170	8.3	2954	9.9	3506	25.8	9165	38.3	13635
160	8.0	3025	9.3	3513	24.3	9178	36.1	13663
150	7.6	3066	8.7	3517	22.8	9193	33.9	13666
140	7.2	3112	8.1	3518	21.3	9205	31.7	13700
120	6.4	3227	7.0	3529	18.3	9247	27.3	13739
100	5.6	3388	5.9	3539	15.3	9281	22.8	13783

15/1 Nominal Ratio

OUTPUT RPM	PT1107		PT2115		PT3203		PT4207	
	Actual Ratio 15.34/1		Actual Ratio 14.63:1		Actual Ratio 15.24:1		Actual Ratio 14.59:1	
	INPUT HP	OUTPUT TORQUE (IN-LB)	INPUT HP	OUTPUT TORQUE (IN-LB)	INPUT HP	OUTPUT TORQUE (IN-LB)	INPUT HP	OUTPUT TORQUE (IN-LB)
140	7.5	3220	11.6	5013	19.7	8496	31.8	13743
130	7.0	3235	11.0	5124	18.7	8689	30.2	14051
120	6.5	3252	10.4	5249	17.7	8899	28.6	14395
100	5.4	3291	9.2	5548	15.5	9402	25.1	15205
80	4.4	3343	7.8	5929	13.3	10051	20.5	15497
60	3.4	3398	6.4	6464	10.5	10558	15.7	15822
40	2.3	3479	4.8	7306	7.2	10891	10.7	16215
30	1.7	3509	3.9	7765	5.4	10951	8.2	16457
20	1.2	3570	2.6	7896	3.7	11133	5.5	16760

25/1 Nominal Ratio

OUTPUT RPM	PT1107		PT2115		PT3203		PT4207	
	Actual Ratio 25.42/1		Actual Ratio 24.39:1		Actual Ratio 24.69:1		Actual Ratio 24.78:1	
	INPUT HP	OUTPUT TORQUE (IN-LB)	INPUT HP	OUTPUT TORQUE (IN-LB)	INPUT HP	OUTPUT TORQUE (IN-LB)	INPUT HP	OUTPUT TORQUE (IN-LB)
85	4.7	3310	8.1	5787	14.2	10093	21.5	15332
75	4.2	3348	7.5	6067	12.7	10245	19.3	15570
65	3.7	3398	6.8	6339	11.2	10416	17.0	15824
55	3.1	3454	6.1	6655	9.6	10594	14.7	16116
45	2.6	3496	5.2	7018	8.0	10810	12.2	16457
35	2.1	3578	4.2	7174	6.4	11029	9.7	16837
25	1.5	3654	3.0	7357	4.6	11205	7.2	17328
15	0.94	3792	1.9	7543	2.8	11415	4.4	17788
5	0.32	3872	0.65	7866	1.0	11617	1.5	18030

Mechanical Ratings G9

INPUT HORSEPOWER AND OUTPUT TORQUE, 1.00 SERVICE FACTOR

9/1 Nominal Ratio

OUTPUT RPM	PT5215		PT6307		PT7315	
	Actual Ratio 8.98:1		Actual Ratio 8.83:1		Actual Ratio 8.91:1	
	INPUT HP	OUTPUT TORQUE (IN-LB)	INPUT HP	OUTPUT TORQUE (IN-LB)	INPUT HP	OUTPUT TORQUE (IN-LB)
200	68.0	20577	95.3	28839	151	45535
190	64.7	20594	90.7	28895	145	46066
180	61.4	20642	86.0	28914	139	46605
170	58.1	20664	81.4	28978	132	47150
160	54.7	20681	76.7	28997	126	47700
150	51.3	20700	72.1	29066	119	48173
140	48.0	20762	67.3	29085	114	49423
120	41.3	20803	57.9	29183	99.8	50339
100	34.6	20904	48.4	29290	84.8	51313

15/1 Nominal Ratio

OUTPUT RPM	PT5215		PT6307		PT7315		PT8407	
	Actual Ratio 15.18:1		Actual Ratio 14.77:1		Actual Ratio 14.84:1		Actual Ratio 14.97:1	
	INPUT HP	OUTPUT TORQUE (IN-LB)	INPUT HP	OUTPUT TORQUE (IN-LB)	INPUT HP	OUTPUT TORQUE (IN-LB)	INPUT HP	OUTPUT TORQUE (IN-LB)
140								
130	44.0	20464	82.9	38583				
120	41.6	20955	77.1	38894	100	50596	163	82270
100	36.6	22132	65.4	39576	88.4	53473	139	83883
80	31.3	23657	53.4	40364	75.7	57222	113	85711
60	25.6	25805	41.0	41294	60.3	60756	87.2	87973
40	18.2	27529	28.1	42444	41.4	62561	60.0	90741
30	13.9	27973	21.4	43180	31.6	63711	45.9	92490
20	9.6	28891	15.0	45227	21.5	65072	31.3	94628

25/1 Nominal Ratio

OUTPUT RPM	PT5215		PT6307		PT7315		PT8407	
	Actual Ratio 25.27:1		Actual Ratio 25.37:1		Actual Ratio 25.09:1		Actual Ratio 24.72:1	
	INPUT HP	OUTPUT TORQUE (IN-LB)	INPUT HP	OUTPUT TORQUE (IN-LB)	INPUT HP	OUTPUT TORQUE (IN-LB)	INPUT HP	OUTPUT TORQUE (IN-LB)
85	32.6	23234	56.0	39890				
75	29.9	24121	50.3	40578	72.1	58197	105	84706
65	27.1	25179	44.4	41338	63.7	59331	94.4	87908
55	24.1	26468	38.4	42188	55.1	60614	81.8	90008
45	20.2	27133	32.1	43160	45.2	60706	68.2	91697
35	16.1	27797	25.6	44306	36.4	62838	53.4	92260
25	11.8	28630	18.9	45620	26.2	63408	38.5	93128
15	7.3	29244	11.8	47395	16.0	64699	23.6	94991
5	2.5	30131	4.0	48282	5.4	65223	8.5	102252



G10 Selection By Input Horsepower

CLASS I SERVICE

HP	Output RPM	Reducer Selection	Minimum Sheave Dia.
0.25	4 ~ 70	PT1107-25 PT1107-15	3.0
	71 ~ 85	PT1107-25 PT1107-15	3.0
	86 ~ 115	PT1107-15 PT1107-09	3.0/4.0
	116 ~ 140	PT1107-15 PT1107-09	3.0/4.0
	141 ~ 200	PT1107-09	4.0
0.33	5 ~ 70	PT1107-25 PT1107-15	3.0
	71 ~ 85	PT1107-25 PT1107-15	3.0
	86 ~ 115	PT1107-15 PT1107-09	3.0/4.0
	116 ~ 140	PT1107-15 PT1107-09	3.0/4.0
	141 ~ 200	PT1107-09	4.0
0.50	4 ~ 6	PT2115-25	3.0
	7 ~ 70	PT1107-25 PT1107-15	3.0
	71 ~ 85	PT1107-25 PT1107-15	3.0
	86 ~ 115	PT1107-15 PT1107-09	3.0/4.0
	116 ~ 140	PT1107-15 PT1107-09	3.0/4.0
	141 ~ 200	PT1107-09	4.0
0.75	4 ~ 5	PT3203-25	4.0
	6 ~ 10	PT2115-25	3.0
	11 ~ 70	PT1107-25 PT1107-15	3.0
	71 ~ 85	PT1107-25 PT1107-15	3.0
	86 ~ 115	PT1107-15 PT1107-09	3.0/4.0
	116 ~ 140	PT1107-15 PT1107-09	3.0/4.0
1	4 ~ 5	PT4207-25	4.6
	6 ~ 7	PT3203-25	4.0
	8 ~ 15	PT2115-25	3.0
	16 ~ 70	PT1107-25 PT1107-15	3.0
	71 ~ 85	PT1107-25 PT1107-15	3.0
	86 ~ 115	PT1107-15 PT1107-09	3.0/4.0
	116 ~ 140	PT1107-15 PT1107-09	3.0/4.0
	141 ~ 200	PT1107-09	4.0
	1.5	4	PT5215-25
5 ~ 7		PT4207-25	4.6
8 ~ 12		PT3203-25	4.0
13 ~ 23		PT2115-25	3.0
24 ~ 70		PT1107-25 PT1107-15	3.0
71 ~ 85		PT1107-25 PT1107-15	3.0
86 ~ 115		PT1107-15 PT1107-09	3.0/4.0
116 ~ 140		PT1107-15 PT1107-09	3.0/4.0
141 ~ 200		PT1107-09	4.0
2	4 ~ 6	PT5215-25	5.4
	7 ~ 10	PT4207-25	4.6
	11 ~ 17	PT3203-25	4.0
	18 ~ 32	PT2115-25 PT2115-15	3.0
	33 ~ 70	PT1107-25 PT1107-15	3.0
	71 ~ 85	PT1107-25 PT1107-15	3.0
	86 ~ 115	PT1107-15 PT1107-09	3.0/4.0
	116 ~ 140	PT1107-15 PT1107-09	3.0/4.0
	141 ~ 200	PT1107-09	4.0

CLASS I SERVICE (cont'd.)

HP	Output RPM	Reducer Selection	Minimum Sheave Dia.
3	4 ~ 5	PT6307-25	6.2
	6 ~ 10	PT5215-25	5.4
	11 ~ 15	PT4207-25	4.6
	16 ~ 26	PT3203-25	4.0
	27 ~ 51	PT2115-25 PT2115-15	3.0
	52 ~ 70	PT1107-25 PT1107-15	3.0
	71 ~ 85	PT1107-25 PT1107-15	3.0
	86 ~ 115	PT1107-15 PT1107-09	3.0/4.0
	116 ~ 140	PT1107-15 PT1107-09	3.0/4.0
	141 ~ 200	PT1107-09	4.0
5	5 ~ 6	PT7315-25	6.2
	7 ~ 9	PT6307-25	6.2
	10 ~ 17	PT5215-25	5.4
	18 ~ 26	PT4207-25 PT4207-15	4.6
	27 ~ 46	PT3203-25 PT3203-15	4.0
	47 ~ 70	PT2115-25 PT2115-15	3.0
	71 ~ 85	PT2115-25 PT2115-15	3.0
	86 ~ 92	PT1107-09 PT2115-15	4.0/3.0
	93 ~ 115	PT1107-15 PT1107-09	3.0/4.0
	116 ~ 140	PT1107-15 PT1107-09	3.0/4.0
7.5	4 ~ 6	PT8407-25	6.2
	7 ~ 9	PT7315-25	6.2
	10 ~ 15	PT6307-25	6.2
	16 ~ 26	PT5215-25	5.4
	27 ~ 40	PT4207-25 PT4207-15	4.6
	41 ~ 70	PT3203-25 PT3203-15	4.0
	71 ~ 74	PT3203-25 PT3203-15	4.0
	75 ~ 85	PT2115-25 PT2115-15	3.0
	86 ~ 95	PT2115-15	3.0
	96 ~ 140	PT2115-15	3.0
10	141 ~ 200	PT2115-15 PT2115-09	5.0
	6 ~ 8	PT8407-25	6.2
	9 ~ 12	PT7315-25	6.2
	13 ~ 20	PT6307-25	6.2
	21 ~ 36	PT5215-25 PT5215-15	5.4
	37 ~ 56	PT4207-25 PT4207-15	4.6
	57 ~ 70	PT3203-25 PT3203-15	4.0
	71 ~ 85	PT3203-25 PT3203-15	4.0
	86 ~ 103	PT3203-15 PT3203-09	4.0/5.0
	104 ~ 115	PT2115-15	3.0
15	116 ~ 140	PT2115-15	3.0
	141 ~ 158	PT3203-09	5.0
	159 ~ 200	PT3203-09	5.0
	9 ~ 13	PT8407-25	6.2
	14 ~ 19	PT7315-25	6.2
	20 ~ 32	PT6307-25 PT6307-15	6.2
	33 ~ 56	PT5215-25 PT5215-15	5.4
	57 ~ 70	PT4207-25 PT4207-15	4.6
	71 ~ 85	PT4207-25 PT4207-15	4.6
	86 ~ 93	PT4207-15 PT4207-09	4.6/6.5
15	94 ~ 115	PT3203-15 PT3203-09*	4.0/5.0
	116 ~ 140	PT3203-15 PT3203-09*	4.0/5.0
	141 ~ 145	PT3203-09*	5.0
	146 ~ 200	PT3203-09*	5.0

*Additional cooling provisions may be required, consult factory with application details.

Selection By Input Horsepower 11

CLASS I SERVICE (cont'd.)

CLASS II SERVICE

HP	Output RPM	Reducer Selection	Minimum Sheave Dia.
20	13 ~ 18	PT8407-25	6.2
	19 ~ 26	PT7315-25 PT7315-15	6.2
	27 ~ 45	PT6307-25 PT6307-15	6.2
	46 ~ 70	PT5215-25 PT5215-15	5.4
	71 ~ 78	PT5215-25 PT5215-15	5.4
	79 ~ 85	PT4207-25 PT4207-15	4.6
	86 ~ 115	PT4207-15 PT4207-09*	4.6/6.5
	116 ~ 140	PT4207-15* PT4207-09*	4.6/6.5
141 ~ 200	PT3203-09*	5.0	
25	16 ~ 23	PT8407-25	6.2
	24 ~ 33	PT7315-25 PT7315-15	6.2
	34 ~ 59	PT6307-25 PT6307-15	6.2
	60 ~ 70	PT5215-25* PT5215-15*	5.4
	71 ~ 80	PT5215-25* PT5215-15*	5.4
	81 ~ 101	PT5215-15* PT5215-09*	5.4
	102 ~ 132	PT4207-15* PT4207-09*	4.6/6.5
	133 ~ 140	PT4207-15* PT4207-09*	4.6/6.5
	141 ~ 163	PT4207-09*	6.5
	164 ~ 200	PT4207-09*	6.5
30	20 ~ 28	PT8407-25 PT8407-15	6.2
	29 ~ 41	PT7315-25 PT7315-15	6.2
	42 ~ 70	PT6307-25 PT6307-15	6.2
	71 ~ 75	PT6307-25 PT6307-15	6.2
	76 ~ 115	PT5215-15* PT5215-09*	5.4/7.0
	116 ~ 125	PT5215-15* PT5215-09*	5.4/7.0
	126 ~ 131	PT4207-09*	6.5
	132 ~ 200	PT4207-09*	6.5
40	26 ~ 38	PT8407-25 PT8407-15	6.2
	39 ~ 57	PT7315-25 PT7315-15	6.2
	58 ~ 70	PT6307-25 PT6307-15	6.2
	71 ~ 81	PT6307-25* PT6307-15*	6.2
	82 ~ 114	PT6307-15* PT6307-09*	6.2/7.0
	115 ~ 125	PT5215-15* PT5215-09*	5.4/7.0
	126 ~ 200	PT5215-09*	7.0
50	33 ~ 49	PT8407-25 PT8407-15	6.2
	50 ~ 70	PT7315-25 PT7315-15	6.2
	71 ~ 74	PT7315-25 PT7315-15	6.2
	75 ~ 125	PT6307-15* PT7315-09*	6.2/7.0
	126 ~ 163	PT7315-09*	7.0
	164 ~ 200	PT6307-09*	7.0
60	40 ~ 60	PT8407-25 PT8407-15	6.2
	61 ~ 70	PT7315-25* PT7315-15*	6.2
	71 ~ 120	PT7315-15* PT7315-09*	6.2/7.0
	121 ~ 131	PT7315-09*	7.0
	132 ~ 200	PT7315-09*	7.0
75	51 ~ 70	PT8407-25 PT8407-15	6.2
	71 ~ 78	PT8407-15*	6.2
	79 ~ 120	PT7315-15* PT7315-09*	6.2/7.0
	121 ~ 200	PT7315-09*	7.0
100	70 ~ 120	PT8407-15*	6.2
	121 ~ 123	PT7315-09*	7.0
	124 ~ 200	PT7315-09*	7.0
125	91 ~ 123	PT8407-15*	6.2

HP	Output RPM	Reducer Selection	Minimum Sheave Dia.
0.25	5 ~ 70	PT1107-25 PT1107-15	3.0
	71 ~ 85	PT1107-25 PT1107-15	3.0
	86 ~ 115	PT1107-15 PT1107-09	3.0/4.0
	116 ~ 140	PT1107-15 PT1107-09	3.0/4.0
	141 ~ 200	PT1107-09	4.0
0.33	4 ~ 6	PT2115-25	3.0
	7 ~ 70	PT1107-25 PT1107-15	3.0
	71 ~ 85	PT1107-25 PT1107-15	3.0
	86 ~ 115	PT1107-15 PT1107-09	3.0/4.0
	116 ~ 140	PT1107-15 PT1107-09	3.0/4.0
0.5	141 ~ 200	PT1107-09	4.0
	4 ~ 5	PT3203-25	4.0
	6 ~ 9	PT2115-25	3.0
	10 ~ 70	PT1107-25 PT1107-15	3.0
	71 ~ 85	PT1107-25 PT1107-15	3.0
0.75	86 ~ 115	PT1107-15 PT1107-09	3.0/4.0
	116 ~ 140	PT1107-15 PT1107-09	3.0/4.0
	141 ~ 200	PT1107-09	4.0
	4 ~ 5	PT4207-25	4.6
	6 ~ 8	PT3203-25	4.0
1	9 ~ 16	PT2115-25	3.0
	17 ~ 70	PT1107-25 PT1107-15	3.0
	71 ~ 85	PT1107-25 PT1107-15	3.0
	86 ~ 115	PT1107-15 PT1107-09	3.0/4.0
	116 ~ 140	PT1107-15 PT1107-09	3.0/4.0
	141 ~ 200	PT1107-09	4.0
	5 ~ 7	PT4207-25	4.6
	8 ~ 11	PT3203-25	4.0
1.5	12 ~ 22	PT2115-25	3.0
	23 ~ 70	PT1107-25 PT1107-15	3.0
	71 ~ 85	PT1107-25 PT1107-15	3.0
	86 ~ 115	PT1107-15 PT1107-09	3.0/4.0
	116 ~ 140	PT1107-15 PT1107-09	3.0/4.0
	141 ~ 200	PT1107-09	4.0
	5 ~ 6	PT5215-25	5.4
	7 ~ 11	PT4207-25	4.6
2	12 ~ 18	PT3203-25	4.0
	19 ~ 34	PT2115-25 PT2115-15	3.0
	35 ~ 70	PT1107-25 PT1107-15	3.0
	71 ~ 85	PT1107-25 PT1107-15	3.0
	86 ~ 115	PT1107-15 PT1107-09	3.0/4.0
	116 ~ 140	PT1107-15 PT1107-09	3.0/4.0
	141 ~ 200	PT1107-09	4.0
	4 ~ 5	PT6307-25	6.2
2	6 ~ 9	PT5215-25	5.4
	10 ~ 14	PT4207-25	4.6
	15 ~ 24	PT3203-25 PT3203-15	4.0
	25 ~ 47	PT2115-25 PT2115-15	3.0
	48 ~ 70	PT1107-25 PT1107-15	3.0
	71 ~ 85	PT1107-25 PT1107-15	3.0
	86 ~ 115	PT1107-15 PT1107-09	3.0/4.0
	116 ~ 140	PT1107-15 PT1107-09	3.0/4.0
	141 ~ 200	PT1107-09	4.0



*Additional cooling provisions may be required, consult factory with application details.

G12 Selection By Input Horsepower

CLASS II SERVICE (cont'd.)

HP	Output RPM	Reducer Selection	Minimum Sheave Dia.
3	4 ~ 5	PT7315-25	6.2
	6 ~ 8	PT6307-25	6.2
	9 ~ 14	PT5215-25	5.4
	15 ~ 22	PT4207-25 PT4207-15	4.6
	23 ~ 38	PT3203-25 PT3203-15	4.0
	39 ~ 70	PT2115-25 PT2115-15	3.0
	71 ~ 75	PT2115-25 PT2115-15	3.0
	76 ~ 85	PT1107-25 PT1107-15	3.0
	86 ~ 115	PT1107-15 PT1107-09	3.0/4.0
	116 ~ 140	PT1107-15 PT1107-09	3.0/4.0
	141 ~ 200	PT1107-09	4.0
5	4 ~ 6	PT8407-25	6.2
	7 ~ 8	PT7315-25	6.2
	9 ~ 14	PT6307-25	6.2
	15 ~ 24	PT5215-25	5.4
	25 ~ 37	PT4207-25 PT4207-15	4.6
	38 ~ 69	PT3203-25 PT3203-15	4.0
	70 ~ 85	PT2115-25 PT2115-15	3.0
	86 ~ 89	PT2115-15 PT2115-09	3.0/5.0
	90 ~ 136	PT2115-15 PT2115-09	3.0/5.0
	137 ~ 140	PT1107-15 PT2115-09	3.0/5.0
	141 ~ 200	PT1107-09	4.0
7.5	6 ~ 9	PT8407-25	6.2
	10 ~ 13	PT7315-25	6.2
	14 ~ 21	PT6307-25	6.2
	22 ~ 38	PT5215-25 PT5215-15	5.4
	39 ~ 59	PT4207-25 PT4207-15	4.6
	60 ~ 70	PT3203-25 PT3203-15	4.0
	71 ~ 85	PT3203-25 PT3203-15	4.0
	86 ~ 110	PT3203-15 PT3203-09	4.0/5.0
	111 ~ 122	PT2115-15 PT3203-09	3.0/5.0
	123 ~ 140	PT2115-15 PT3203-09	3.0/5.0
	141 ~ 183	PT3203-09	5.0
184 ~ 200	PT2115-09	5.0	
10	8 ~ 12	PT8407-25	6.2
	13 ~ 18	PT7315-25	6.2
	19 ~ 29	PT6307-25 PT6307-15	6.2
	30 ~ 52	PT5215-25 PT5215-15	5.4
	53 ~ 70	PT4207-25 PT4207-15	4.6
	71 ~ 84	PT4207-25 PT4207-15	4.6
	85 ~ 130	PT3203-15 PT3203-09	4.0/5.0
	131 ~ 140	PT3203-15 PT3203-09	4.0/5.0
	141 ~ 200	PT3203-09	5.0

CLASS II SERVICE (cont'd.)

HP	Output RPM	Reducer Selection	Minimum Sheave Dia.	
15	13 ~ 19	PT8407-25	6.2	
	20 ~ 27	PT7315-25	6.2	
	28 ~ 47	PT6307-25 PT6307-15	6.2	
	48 ~ 70	PT5215-25 PT5215-15	5.4	
	71 ~ 82	PT5215-25 PT5215-15	5.4	
	83 ~ 117	PT4207-15 PT4207-09	4.6/6.5	
	118 ~ 140	PT4207-15 PT4207-09	4.6/6.5	
	141 ~ 150	PT4207-09	6.5	
	151 ~ 200	PT3203-09*	5.0	
	20	18 ~ 26	PT8407-25	6.2
		27 ~ 38	PT7315-25 PT7315-15	6.2
39 ~ 68		PT6307-25 PT6307-15	6.2	
69 ~ 80		PT5215-25 PT5215-15	5.4	
81 ~ 89		PT5215-15	5.4	
91 ~ 117		PT5215-15* PT5215-09*	5.4/7.0	
118 ~ 125		PT4207-15* PT4207-09*	4.6/6.5	
25	126 ~ 200	PT4207-09*	6.5	
	23 ~ 33	PT8407-25 PT8407-15	6.2	
	34 ~ 49	PT7315-25 PT7315-15	6.2	
	50 ~ 80	PT6307-25 PT6307-15	6.2	
	81 ~ 94	PT6307-15 PT6307-09	6.2/7.0	
	95 ~ 125	PT5215-15* PT5215-09*	5.4/7.0	
	126 ~ 174	PT5215-09*	7.0	
	175 ~ 200	PT4207-09*	6.5	
	30	28 ~ 41	PT8407-25 PT8407-15	6.2
		42 ~ 60	PT7315-25 PT7315-15	6.2
		61 ~ 76	PT6307-25 PT6307-15	6.2
77 ~ 89		PT6307-15 PT6307-09	6.2/7.0	
90 ~ 125		PT6307-15* PT6307-09*	6.2/7.0	
126 ~ 200		PT5215-09*	7.0	
40		37 ~ 56	PT8407-25 PT8407-15	6.2
	57 ~ 75	PT7315-25 PT7315-15	6.2	
	76 ~ 88	PT7315-15	6.2	
	89 ~ 114	PT6307-15*	6.2	
	115 ~ 120	PT6307-15* PT6307-09*	6.2/7.0	
	121 ~ 200	PT6307-09*	7.0	
	50	47 ~ 70	PT8407-25 PT8407-15	6.2
71 ~ 72		PT8407-25 PT8407-15	6.2	
73 ~ 95		PT7315-15*	6.2	
96 ~ 110		PT7315-15* PT7315-09	6.2/7.0	
111 ~ 120		PT7315-15* PT7315-09*	6.2/7.0	
121 ~ 179		PT7315-09*	7.0	
180 ~ 200		PT6307-09*	7.0	
60	57 ~ 70	PT8407-25 PT8407-15	6.2	
	71 ~ 75	PT8407-25 PT8407-15	6.2	
	76 ~ 89	PT8407-15	6.2	
	90 ~ 120	PT7315-15* PT7315-09*	6.2/7.0	
	121 ~ 200	PT7315-09*	7.0	
	75	74 ~ 75	PT8407-25 PT8407-15	6.2
76 ~ 120		PT8407-15*	6.2	
121 ~ 133		PT7315-09*	7.0	
134 ~ 200		PT7315-09*	7.0	
100		104 ~ 120	PT8407-15*	6.2
	181 ~ 200	PT7315-09*	7.0	

*Additional cooling provisions may be required, consult factory with application details.

Selection By Input Horsepower G13

CLASS III SERVICE

CLASS III SERVICE (cont'd.)

HP	Output RPM	Reducer Selection	Minimum Sheave Dia.
0.25	4 ~ 6	PT2115-25	3.0
	7 ~ 70	PT1107-25 PT1107-15	3.0
	71 ~ 85	PT1107-25 PT1107-15	3.0
	86 ~ 89	PT1107-15 PT1107-09	3.0/4.0
	90 ~ 115	PT1107-15 PT1107-09	3.0/4.0
	116 ~ 140	PT1107-15 PT1107-09	3.0/4.0
	141 ~ 200	PT1107-09	4.0
0.33	5 ~ 9	PT2115-25	3.0
	10 ~ 70	PT1107-25 PT1107-15	3.0
	71 ~ 85	PT1107-25 PT1107-15	3.0
	86 ~ 115	PT1107-15 PT1107-09	3.0/4.0
	116 ~ 140	PT1107-15 PT1107-09	3.0/4.0
141 ~ 200	PT1107-09	4.0	
0.50	4 ~ 5	PT4207-25	4.6
	6 ~ 7	PT3203-25	4.0
	8 ~ 15	PT2115-25	3.0
	16 ~ 70	PT1107-25 PT1107-15	3.0
	71 ~ 85	PT1107-25 PT1107-15	3.0
	86 ~ 115	PT1107-15 PT1107-09	3.0/4.0
	116 ~ 140	PT1107-15 PT1107-09	3.0/4.0
141 ~ 200	PT1107-09	4.0	
0.75	4	PT5215-25	5.4
	5 ~ 7	PT4207-25	4.6
	8 ~ 12	PT3203-25	4.0
	13 ~ 23	PT2115-25	3.0
	24 ~ 70	PT1107-25 PT1107-15	3.0
	71 ~ 85	PT1107-25 PT1107-15	3.0
	86 ~ 115	PT1107-15 PT1107-09	3.0/4.0
	116 ~ 140	PT1107-15 PT1107-09	3.0/4.0
141 ~ 200	PT1107-09	4.0	
1.00	4 ~ 6	PT5215-25	5.4
	7 ~ 10	PT4207-25	4.6
	11 ~ 17	PT3203-25	4.0
	18 ~ 32	PT2115-25	3.0
	33 ~ 70	PT1107-25 PT1107-15	3.0
	71 ~ 85	PT1107-25 PT1107-15	3.0
	86 ~ 115	PT1107-15 PT1107-09	3.0/4.0
	116 ~ 140	PT1107-15 PT1107-09	3.0/4.0
141 ~ 200	PT1107-09	4.0	
1.5	4 ~ 5	PT6307-25	6.2
	6 ~ 10	PT5215-25	5.4
	11 ~ 15	PT4207-25	4.6
	16 ~ 26	PT3203-25	4.0
	27 ~ 51	PT2115-25 PT2115-15	3.0
	52 ~ 70	PT1107-25 PT1107-15	3.0
	71 ~ 85	PT1107-25 PT1107-15	3.0
	86 ~ 115	PT1107-15 PT1107-09	3.0/4.0
	116 ~ 140	PT1107-15 PT1107-09	3.0/4.0
	141 ~ 200	PT1107-09	4.0

HP	Output RPM	Reducer Selection	Minimum Sheave Dia.
2	5 ~ 7	PT6307-25	6.2
	8 ~ 13	PT5215-25	5.4
	14 ~ 21	PT4207-25	4.6
	22 ~ 36	PT3203-25 PT3203-15	4.0
	37 ~ 71	PT2115-25 PT2115-15	3.0
	72 ~ 85	PT1107-25 PT1107-15	3.0
	86 ~ 115	PT1107-15 PT1107-09	3.0/4.0
	116 ~ 140	PT1107-15 PT1107-09	3.0/4.0
	141 ~ 200	PT1107-09	4.0
3	4 ~ 5	PT8407-25	6.2
	6 ~ 7	PT7315-25	6.2
	8 ~ 12	PT6307-25	6.2
	13 ~ 20	PT5215-25	5.4
	21 ~ 32	PT4207-25 PT4207-15	4.6
	33 ~ 57	PT3203-25 PT3203-15	4.0
	58 ~ 70	PT2115-25 PT2115-15	3.0
	71 ~ 85	PT2115-25 PT2115-15	3.0
	86 ~ 89	PT2115-15 PT2115-09	3.0/5.0
	90 ~ 113	PT2115-15 PT2115-09	3.0/5.0
	114 ~ 140	PT1107-15 PT1107-09	3.0/4.0
141 ~ 200	PT1107-09	4.0	
5	6 ~ 8	PT8407-25	6.2
	9 ~ 12	PT7315-25	6.2
	13 ~ 20	PT6307-25	6.2
	21 ~ 36	PT5215-25 PT5215-15	5.4
	37 ~ 56	PT4207-25 PT4207-15	4.6
	57 ~ 70	PT3203-25 PT3203-15	4.0
	71 ~ 85	PT3203-25 PT3203-15	4.0
	86 ~ 103	PT3203-15 PT3203-09	4.0/5.0
	104 ~ 114	PT2115-15 PT3203-09	3.0/5.0
	115 ~ 140	PT2115-15 PT2115-09	3.0/5.0
	141 ~ 167	PT2115-09	5.0
	168 ~ 200	PT2115-09	5.0
	7.5	9 ~ 13	PT8407-25
14 ~ 19		PT7315-25	6.2
20 ~ 32		PT6307-25 PT6307-15	6.2
33 ~ 56		PT5215-25 PT5215-15	5.4
57 ~ 70		PT4207-25 PT4207-15	4.6
71 ~ 85		PT4207-25 PT4207-15	4.6
86 ~ 93		PT4207-15 PT4207-09	4.6/6.5
94 ~ 140		PT3203-15 PT3203-09	4.0/5.0
141 ~ 144		PT3203-09	5.0
145 ~ 200		PT3203-09	5.0



*Additional cooling provisions may be required, consult factory with application details.

G14 Selection By Input Horsepower

CLASS III SERVICE (cont'd.)

HP	Output RPM	Reducer Selection	Minimum Sheave Dia.
10	13 ~ 18	PT8407-25	6.2
	19 ~ 26	PT7315-25 PT7315-15	6.2
	27 ~ 45	PT6307-25 PT6307-15	6.2
	46 ~ 70	PT5215-25 PT5215-15	5.4
	71 ~ 78	PT5215-25 PT5215-15	5.4
	79 ~ 92	PT4207-15	4.6
	93 ~ 105	PT4207-15 PT4207-09	4.6/6.5
	106 ~ 141	PT4207-15 PT4207-09	4.6/6.5
	142 ~ 200	PT3203-09	5.0
15	20 ~ 28	PT8407-25 PT8407-15	6.2
	29 ~ 41	PT7315-25 PT7315-15	6.2
	42 ~ 70	PT6307-25 PT6307-15	6.2
	71 ~ 75	PT6307-25 PT6307-15	6.2
	76 ~ 93	PT5215-15	5.4
	94 ~ 115	PT5215-15 PT5215-09	5.4/7.0
	116 ~ 125	PT5215-15 PT5215-09	5.4/7.0
	126 ~ 131	PT5215-09	7.0
	132 ~ 200	PT4207-09	6.5
20	26 ~ 38	PT8407-25 PT8407-15	6.2
	39 ~ 57	PT7315-25 PT7315-15	6.2
	58 ~ 70	PT6307-25 PT6307-15	6.2
	71 ~ 114	PT6307-15 PT6307-09	6.2/7.0
	115 ~ 125	PT5215-15* PT5215-09*	5.4/7.0
	126 ~ 200	PT5215-09*	7.0
25	33 ~ 49	PT8407-25 PT8407-15	6.2
	50 ~ 70	PT7315-25 PT7315-15	6.2
	71 ~ 74	PT7315-25 PT7315-15	6.2
	75 ~ 104	PT6307-15	6.2
	105 ~ 113	PT6307-15* PT6307-09	6.2/7.0
	114 ~ 125	PT6307-15* PT6307-09*	6.2/7.0
	126 ~ 200	PT6307-09*	7.0
30	40 ~ 60	PT8407-25 PT8407-15	6.2
	61 ~ 70	PT7315-25 PT7315-15	6.2
	71 ~ 98	PT7315-15	6.2
	99 ~ 125	PT6307-15	6.2
	126 ~ 131	PT6307-09*	7.0
	132 ~ 200	PT6307-09*	7.0
	40	54 ~ 70	PT8407-25 PT8407-15
71 ~ 84		PT8407-15	6.2
85 ~ 89		PT7315-15 PT7315-09	6.2/7.0
90 ~ 120		PT7315-15* PT7315-09	6.2/7.0
121 ~ 200		PT7315-09*	7.0
50	70 ~ 75	PT8407-25 PT8407-15	6.2
	76 ~ 110	PT8407-15	6.2
	111 ~ 120	PT7315-15* PT7315-09*	6.2/7.0
	121 ~ 123	PT7315-09*	7.0
	124 ~ 200	PT7315-09*	7.0
60	86 ~ 115	PT8407-15	6.2
	142 ~ 161	PT7315-09*	7.0
	162 ~ 200	PT7315-09*	7.0

*Additional cooling provisions may be required, consult factory with application details.

POWER TORQUE® Shaft Mount Reducer Dimensions G15

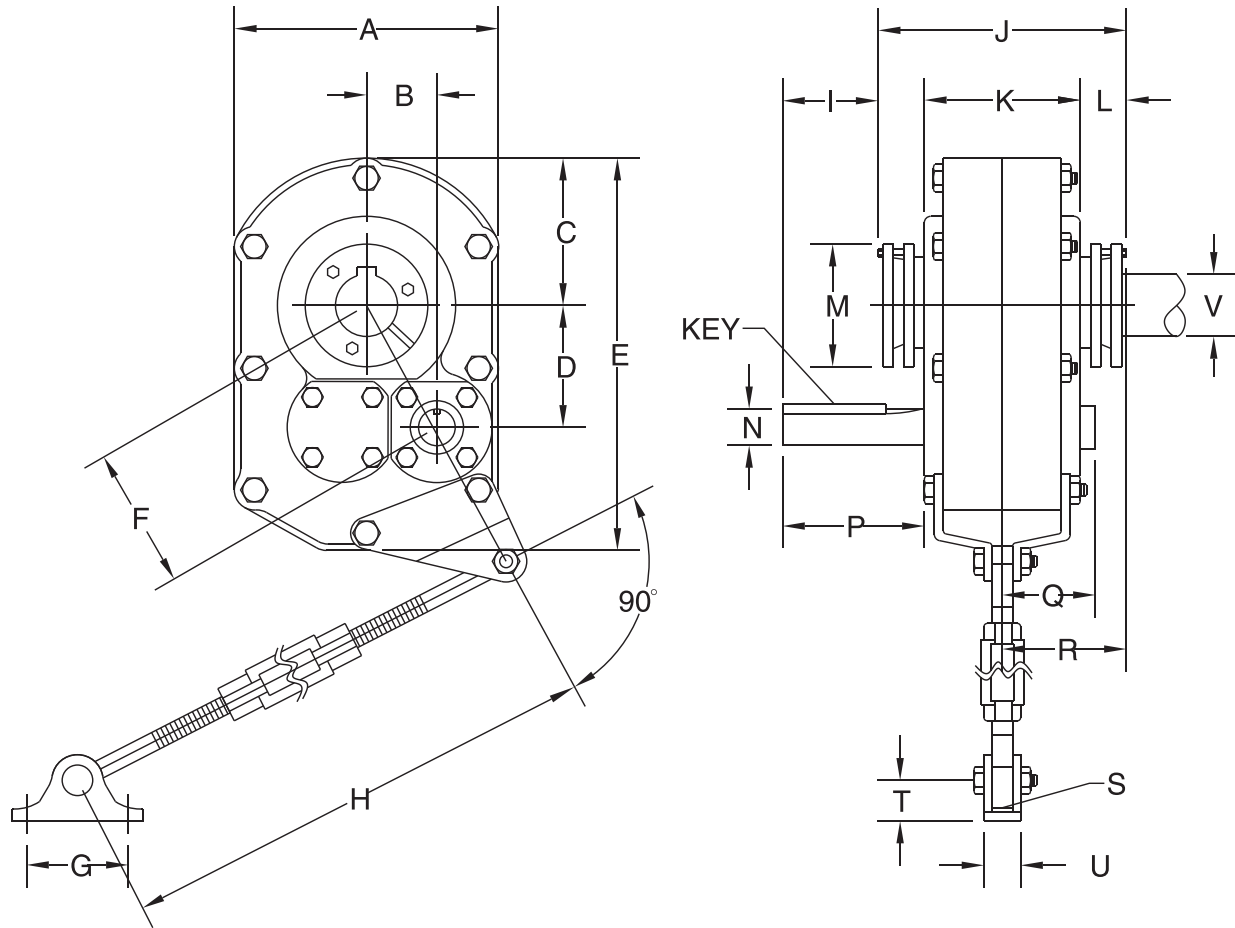

Model	A	B	C	D	E	F	G	H min/max	I	J	K
PT1107	7.13	1.91	3.75	3.18	9.94	3.71	2.50	23.81/29.63	2.03	7.06	4.06
PT2115	8.38	2.14	4.09	3.75	11.41	4.32	3.00	26.94/32.94	2.22	7.32	4.50
PT3203	9.25	2.33	4.84	4.17	12.88	4.78	3.00	26.94/32.94	2.34	9.22	5.63
PT4207	10.38	2.76	5.50	4.79	15.13	5.53	4.00	29.19/35.14	3.44	9.98	6.13
PT5215	13.13	3.04	6.56	5.67	18.31	6.43	4.00	29.19/35.19	3.44	10.52	6.31
PT6307	15.43	4.09	7.56	6.73	21.31	7.88	4.75	29.19/35.19	3.73	11.53	6.88
PT7315	18.75	5.11	9.38	8.30	25.94	9.74	4.75	29.44/35.44	3.75	12.85	7.75
PT8407	20.25	6.03	10.13	9.50	28.25	11.25	4.75	30.00/36.00	4.31	14.03	8.37

Model	L	M	Q	R	S	T	U	V Max Dia	Input Shaft			Approximate Weight (LB)
									N Dia	P	Key	
PT1107	1.30	3.25	2.67	3.55	0.38	0.94	1.06	1 7/16	0.75	3.30	3/16x3/16x1-7/8	45
PT2115	1.40	4.06	2.89	3.68	0.44	1.06	1.25	1 15/16	1.13	3.59	1/4x1/4x2-1/2	58
PT3203	1.59	4.38	3.30	3.72	0.44	1.06	1.25	2 3/16	1.25	4.34	1/4x1/4x2-7/8	98
PT4207	1.72	4.81	3.41	3.91	0.50	1.75	1.44	2 7/16	1.44	5.57	3/8x3/8x4-1/16	139
PT5215	1.91	5.63	4.45	5.05	0.50	1.75	1.44	2 15/16	1.94	5.74	1/2x1/2x4-1/2	207
PT6307	2.30	6.13	4.57	5.73	0.63	2.00	2.75	3 7/16	2.19	6.08	1/2x1/2x4-1/2	285
PT7315	2.50	7.25	4.69	6.38	0.63	2.00	2.75	3 15/16	2.44	6.35	5/8x5/8x4-3/4	462
PT8407	2.86	7.75	5.85	7.04	0.75	3.13	4.00	4 7/16	2.44	7.11	5/8x5/8x5-3/8	633



G16 POWER TORQUE® Screw Conveyor Drive Accessories

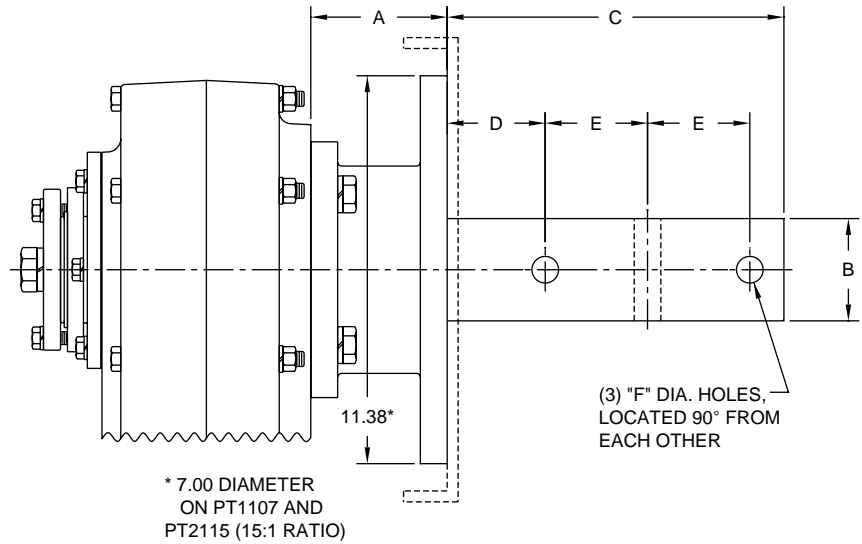
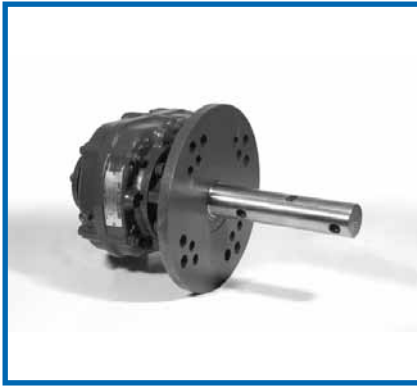

Shaft Mount Model	Adapter Flanges		Drive Shafts						
	Weights (lbs.)	A	Weight (lbs.)	B	C	D	E	F	Screw Size
PT1107	13	3.22	14	1.500	9.00	2.12	3.00	17/32	6
			14	1.500	9.00	2.12	3.00	17/32	9
	27	3.22	17	2.000	9.00	2.12	3.00	21/32	9, 12
			22	2.437	9.69	2.75	3.00	21/32	12, 14
			29	3.000	9.88	2.88	3.00	25/32	12 - 20
PT2115	15	3.56	15	1.500	9.00	2.12	3.00	17/32	6
			15	1.500	9.00	2.12	3.00	17/32	9
	25	3.56	18	2.000	9.00	2.12	3.00	21/32	9, 12
			23	2.437	9.69	2.75	3.00	21/32	12, 14
			30	3.000	9.88	2.88	3.00	25/32	12 - 20
PT3203	29	3.69	20	1.500	9.00	2.12	3.00	17/32	9
			23	2.000	9.00	2.12	3.00	21/32	9, 12
			28	2.437	9.69	2.75	3.00	21/32	12, 14
			35	3.000	9.88	2.88	3.00	25/32	12 - 20
PT4207	33	4.00	24	1.500	9.00	2.12	3.00	17/32	9
			27	2.000	9.00	2.12	3.00	21/32	9, 12
			32	2.437	9.69	2.75	3.00	21/32	12, 14
			39	3.000	9.88	2.88	3.00	25/32	12 - 20
			53	3.437	13.13	3.88	4.00	29/32	18 - 24
PT5215	43	4.25	37	2.000	9.00	2.12	3.00	21/32	9, 12
			42	2.437	9.69	2.75	3.00	21/32	12, 14
			49	3.000	9.88	2.88	3.00	25/32	12 - 20
			63	3.437	13.13	3.88	4.00	29/32	18 - 24
PT6307	56	5.50	57	2.437	9.69	2.75	3.00	21/32	12, 14
			64	3.000	9.88	2.88	3.00	25/32	12 - 20
			78	3.437	13.13	3.88	4.00	29/32	18 - 24
PT7315	72	6.50	73	2.437	9.69	2.75	3.00	21/32	12, 14
			80	3.000	9.88	2.88	3.00	25/32	12 - 20
			94	3.437	13.13	3.88	4.00	29/32	18 - 24

Adapter Flanges

Conform to CEMA standards. Bolt-on design allows easy mounting open center for contaminate dropout.



Drive Shafts

Conform to CEMA dimensional standards. Machined from high strength alloy steel. Easy installation into standard hollow bore.



Auxiliary Seal Kits

Available upon request, consult factory for details

Phone: (605) 225-0360

FOOTE-JONES

Fax: (605) 225-0567



TAPERED BUSHING KITS

- Flanged bushing mount
- Removal screws allow for easy demounting
- Ductile Iron material for shock resistance
- Clamp fit, no setscrews
- Split design eliminates seizing problems
- Kits include two bushings, key and mounting hardware

Shaft Mount Model	Bore Size	Weight (lbs.)
PT1107	1-7/16	2.8
	1-3/8	2.9
	1-5/16	2.9
	1-1/4	3
PT2115	1-15/16	3
	1-3/4	3.4
	1-11/16	3.5
	1-5/8	3.6
PT3203	2-3/16	3.7
	2	4.3
	1-15/16	4.6
PT4207	1-7/8	4.8
	2-7/16	5.9
	2-1/4	6.4
	2-3/16	6.8
PT5215	2-1/8	7.1
	2-15/16	7.8
	2-11/16	7.9
	2-1/2	8.5
PT6307	2-7/16	8.6
	3-7/16	9
	3	11.4
	2-15/16	11.7
PT7315	2-7/8	12.4
	3-15/16	12.9
	3-7/16	13.9
	3-3/16	16.8
PT8407	3	19.2
	4-7/16	15.1
	4-3/16	17.4
	3-15/16	20.2
	3-7/16	25.6



BACKSTOP KITS

- Quick installation on input shaft
- Internally installed, sealed from contamination
- Lubricated by internal gear lubricant
- Designed to operate in either direction

Shaft Mount Model	Weight (lbs.)
PT1107 & PT2115	1
PT2115*	1
PT3203	1.1
PT4207	1.2
PT5215	2.2
PT6307	2.5
PT7315	2.8
PT8407	3.8

*Use for PT2115 without endcaps (ball bearing)

G18 POWER TORQUE® Accessories

VERTICAL MOTOR MOUNTS

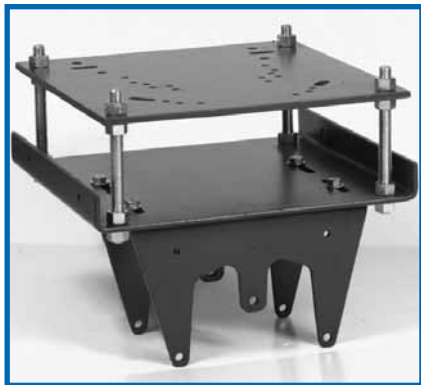

All-Steel construction for rigidity
 Compact design eliminates need for motor base
 Top plate adjusts for easy tensioning of drive belt
 Mounting holes provided match NEMA standards

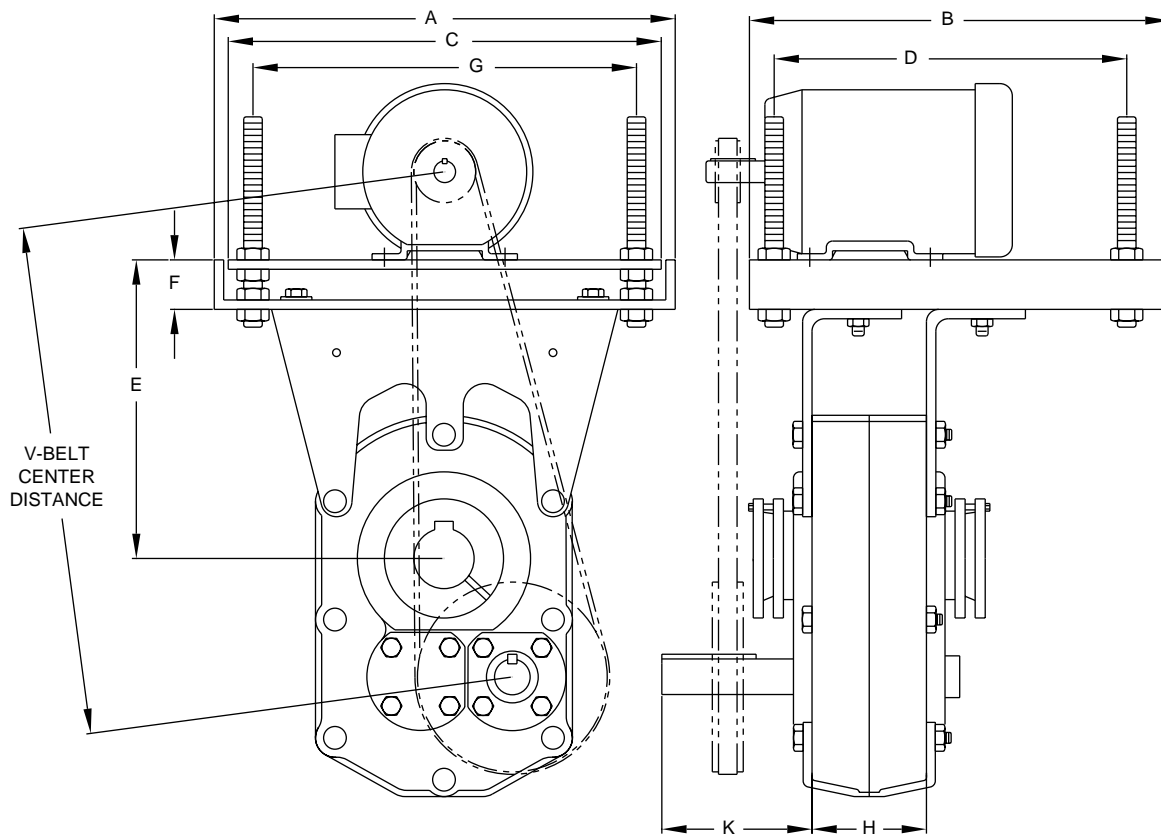

NOTE: SHIELDS/GUARDS NOT SHOWN FOR ILLUSTRATION PURPOSES

VERTICAL MOTOR MOUNTS

		V-Belt Center Distance for NEMA Motor Frames													
Shaft Mount	NEMA Motor	56-140 Min	56-140 Max	180 Min	180 Max	210 Min	210 Max	250 Min	250 Max	280 Min	280 Max	320 Min	320 Max	360 Min	360 Max
PT1107	56C-215T	17.6	21.0	18.5	22.0	19.3	22.7								
PT2115	56C-215T	18.7	22.1	19.7	23.1	20.5	23.9								
PT3203	56C-215T	20.2	23.6	21.2	24.6	22.0	25.3								
PT3203	143T-286T	20.4	23.8	21.4	24.8	22.2	25.5	23.2	26.5	23.9	27.2				
PT4207	143T-286T	21.2	25.2	22.2	26.2	23.0	26.9	23.9	27.9	24.7	28.7				
PT4207	143T-326T	21.3	25.3	22.3	26.3	23.1	27.0	24.0	28.0	24.8	28.8	25.8	29.8		
PT5215	143T-286T	22.7	26.6	23.7	27.6	24.4	28.4	25.4	29.4	26.2	30.1				
PT5215	143T-326T	22.8	26.7	23.8	27.7	24.5	28.5	25.5	29.5	26.3	30.2	27.3	31.2		
PT6307	143T-326T	25.9	29.7	26.9	30.7	27.6	31.4	28.6	32.4	29.4	33.2	30.4	34.2		
PT7315	143T-365T	30.6	34.4	31.6	35.4	32.4	36.2	33.4	37.2	34.1	37.9	35.1	38.9	36.1	39.9
PT8407	143T-365T	31.9	36.4	32.9	37.4	33.7	38.2	34.7	39.2	35.4	39.9	36.4	40.9	37.4	41.9

Shaft Mount	Weight (lbs.)	A	B	C	D	E		F	G	H	J	K
						Min	Max					
PT1107	35	14.63	11.00	13.50	9.25	10.0	14.2	1.59	12.00	3.38	5/8x7	3.88
PT2115	35	14.63	11.00	13.50	9.25	10.6	14.8	1.59	12.00	3.38	5/8x7	4.18
PT3203	35	14.63	11.00	13.50	9.25	11.6	15.9	1.59	12.00	4.25	5/8x8	4.88
PT3203	77	18.63	17.00	17.50	14.25	11.8	16.0	1.78	15.50	4.25	3/4x8	4.88
PT4207	87	18.63	17.00	17.50	14.25	12.0	16.7	1.78	15.50	4.63	3/4x8	6.13
PT4207	121	20.50	18.50	19.25	16.50	12.0	16.8	1.84	17.50	4.63	3/4x8	6.13
PT5215	84	18.63	17.00	17.50	14.25	12.5	17.3	1.78	15.50	4.13	3/4x8	6.65
PT5215	118	20.50	18.50	19.25	16.50	12.5	17.3	1.84	17.50	4.13	3/4x8	6.65
PT6307	118	20.50	18.50	19.25	16.50	14.6	19.3	1.84	17.50	4.50	3/4x8	7.31
PT7315	148	22.50	19.00	21.25	16.50	17.6	22.1	2.50	19.25	4.75	1x9	7.81
PT8407	148	22.50	19.00	21.25	16.50	18.3	22.8	2.50	19.25	4.75	1x9	8.81

VERTICAL LONG MOTOR MOUNTS

		V-Belt Center Distance for NEMA Motor Frames													
Shaft Mount	NEMA Motor	56-140 Min	56-140 Max	180 Min	180 Max	210 Min	210 Max	250 Min	250 Max	280 Min	280 Max	320 Min	320 Max	360 Min	360 Max
PT1107	56C-215T	20.6	24.0	21.5	25.0	22.3	25.7								
PT2115	56C-215T	21.7	25.1	22.7	26.1	23.5	26.9								
PT3203	56C-215T	23.2	26.6	24.2	27.6	25.0	28.3								
PT3203	143T-286T	23.4	26.8	24.4	27.8	25.2	28.5	26.2	29.5	26.9	30.2				
PT4207	143T-286T	25.7	29.7	26.7	30.7	27.5	31.4	28.4	32.4	29.2	33.2				
PT4207	143T-326T	25.8	29.8	26.8	30.8	27.6	31.5	28.5	32.5	29.3	33.3	30.3	34.3		
PT5215	143T-286T	29.5	33.4	30.5	34.4	31.2	35.2	32.2	36.2	33.0	36.9				
PT5215	143T-326T	29.5	33.4	30.5	34.4	31.2	35.2	32.2	36.2	33.0	36.9	34.0	37.9		
PT6307	143T-326T	39.9	43.7	40.9	44.7	51.6	45.4	42.6	46.4	43.4	47.2	44.4	48.2		
PT7315	143T-365T	45.6	49.4	46.6	50.4	47.4	51.2	48.4	52.2	49.1	52.9	50.1	53.9	51.1	54.9
PT8407	143T-365T	44.9	49.4	45.9	50.4	46.7	51.2	47.7	52.2	48.4	52.9	49.4	53.9	50.4	54.9

Shaft Mount	Weight (lbs.)	A	B	C	D	E		F	G	H	J	K
						Min	Max					
PT1107	41	14.63	11.00	13.50	9.25	13.0	17.2	1.59	12.00	3.38	5/8x7	3.88
PT2115	41	14.63	11.00	13.50	9.25	13.6	17.8	1.59	12.00	3.38	5/8x7	4.18
PT3203	41	14.63	11.00	13.50	9.25	14.6	18.8	1.59	12.00	4.25	5/8x8	4.88
PT3203	83	18.63	17.00	17.50	14.25	14.8	19.0	1.78	15.50	4.25	3/4x8	4.88
PT4207	95	18.63	17.00	17.50	14.25	16.5	21.2	1.78	15.50	4.63	3/4x8	6.13
PT4207	129	20.50	18.50	19.25	16.50	16.5	21.3	1.84	17.50	4.63	3/4x8	6.13
PT5215	106	18.63	17.00	17.50	14.25	19.3	24.0	1.78	15.50	4.13	3/4x8	6.65
PT5215	137	20.50	18.50	19.25	16.50	19.3	24.0	1.84	17.50	4.13	3/4x8	6.65
PT6307	142	20.50	18.50	19.25	16.50	28.6	33.3	1.84	17.50	4.50	3/4x8	7.31
PT7315	206	22.50	19.00	21.25	16.50	32.5	37.2	2.50	19.25	4.75	1x9	7.81
PT8407	206	22.50	19.00	21.25	16.50	31.6	36.1	2.50	19.25	4.75	1x9	8.81



G20 POWER TORQUE® Accessories

HORIZONTAL MOTOR MOUNTS



- All-Steel construction for rigidity
- Compact design eliminates need for motor base
- Top plate adjusts for easy tensioning of drive belt
- Mounting holes provided match NEMA standards

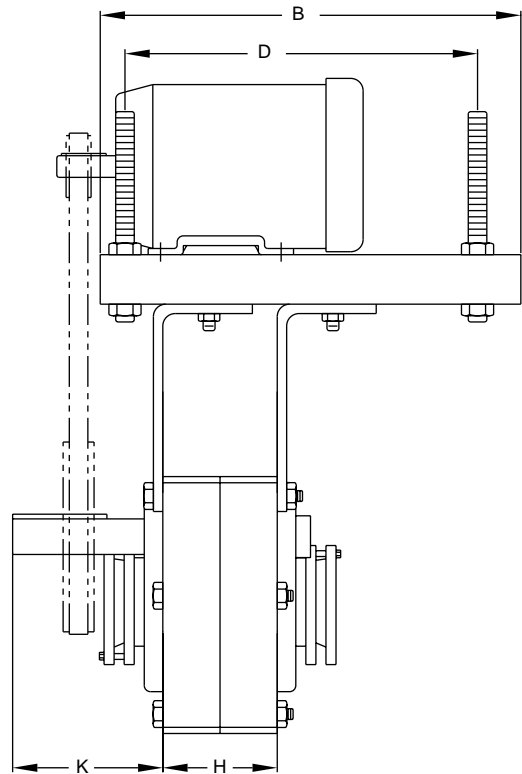
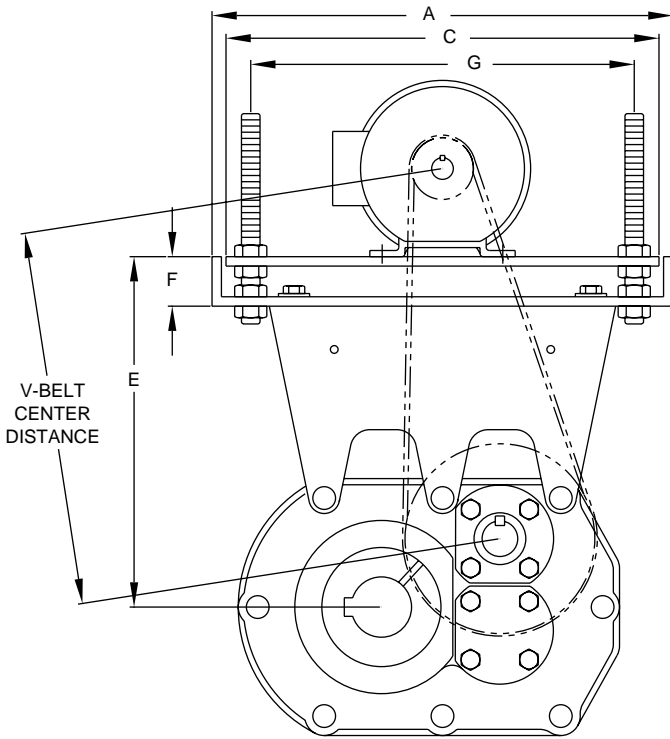

NOTE: SHIELDS/GUARDS NOT SHOWN FOR ILLUSTRATION PURPOSES

HORIZONTAL MOTOR MOUNTS

Shaft Mount	NEMA Motor	V-Belt Center Distance for NEMA Motor Frames														
		Screw Diameters	56-140 Min	56-140 Max	180 Min	180 Max	210 Min	210 Max	250 Min	250 Max	280 Min	280 Max	320 Min	320 Max	360 Min	360 Max
PT1107	56C-215T	6 - 12	13.5	17.0	14.5	18.0	15.3	19.0								
PT2115	56C-215T	6 - 14	14.9	18.3	15.9	19.3	16.6	20.0								
PT3203	56C-215T	6 - 16	15.8	19.3	16.8	20.3	17.6	21.0								
PT3203	143T-286T	6 - 16	16.0	19.5	17.0	20.5	17.8	21.2	18.8	22.2	19.6	22.9				
PT4207	143T-286T	9 - 18	16.9	21.0	17.9	22.0	18.6	22.7	19.6	23.7	20.4	24.5	21.4	25.4		
PT4207	143T-326T	9 - 18	16.9	21.0	17.9	22.0	18.6	22.7	19.6	23.7	20.4	24.5	21.4	25.4		
PT5215	143T-286T	9 - 18	16.6	20.7	17.6	21.7	18.4	22.4	19.4	23.4	20.0	24.2				
PT5215	143T-326T	9 - 18	16.6	20.7	17.6	21.7	18.4	22.4	19.4	23.4	20.0	24.2	21.1	25.2		
PT6307	143T-326T	12 - 20	17.0	21.0	18.0	22.0	18.8	22.8	19.7	23.8	20.5	24.5	21.5	25.5		
PT7315	143T-365T	12 - 20	22.1	25.6	23.1	26.5	23.8	27.3	24.8	28.3	25.6	29.0	26.6	30.0	27.5	31.0
PT8407	143T-365T	NA	16.1	20.6	17.1	21.6	17.9	22.4	18.9	23.4	19.6	24.1	20.6	25.1	21.6	26.1

Shaft Mount	Weight (lbs.)	E										
		A	B	C	D	Min	Max	F	G	H	J	K
PT1107	39	14.63	11.00	13.50	9.25	11.1	15.3	1.59	12.00	3.38	5/8x7	3.88
PT2115	40	14.63	11.00	13.50	9.25	12.6	16.8	1.59	12.00	3.38	5/8x7	4.18
PT3203	41	14.63	11.00	13.50	9.25	13.8	18.0	1.59	12.00	4.25	5/8x8	4.88
PT3203	83	18.63	17.00	17.50	14.25	14.0	18.2	1.78	15.50	4.25	3/4x8	4.88
PT4207	97	18.63	17.00	17.50	14.25	15.3	20.1	1.78	15.50	4.63	3/4x8	6.13
PT4207	121	20.50	18.50	19.25	16.50	15.3	20.1	1.84	17.50	4.63	3/4x8	6.13
PT5215	95	18.63	17.00	17.50	14.25	15.3	20.1	1.78	15.50	4.13	3/4x8	6.65
PT5215	122	20.50	18.50	19.25	16.50	15.3	20.1	1.84	17.50	4.13	3/4x8	6.65
PT6307	123	20.50	18.50	19.25	16.50	16.7	21.4	1.84	17.50	4.50	3/4x8	7.31
PT7315	148	22.50	19.00	21.25	16.50	17.5	21.7	2.50	19.25	4.75	1x9	7.81
PT8407	148	22.50	19.00	21.25	16.50	18.3	22.8	2.50	19.25	4.75	1x9	7.81

HORIZONTAL LONG MOTOR MOUNTS

Shaft Mount	NEMA Motor	V-Belt Center Distance for NEMA Motor Frames														
		Screw Diameters	56-140 Min	56-140 Max	180 Min	180 Max	210 Min	210 Max	250 Min	250 Max	280 Min	280 Max	320 Min	320 Max	360 Min	360 Max
PT1107	56C-215T	14 - 20	19.5	22.9	20.5	23.9	21.2	24.7								
PT2115	56C-215T	16 - 20	20.9	24.3	21.9	25.3	22.6	26.0								
PT3203	56C-215T	18 - 20	21.8	25.3	22.8	26.3	23.6	27.0								
PT3203	143T-286T	18 - 20	22.0	25.5	23.0	26.5	23.8	27.2	24.8	28.2	25.6	28.9				
PT4207	143T-286T	20 - 24	23.2	27.0	24.2	28.0	24.9	28.6	25.9	29.6	26.7	30.4				
PT4207	143T-326T	20 - 24	23.2	27.0	24.2	28.0	24.9	28.6	25.9	29.6	26.7	30.4	27.4	31.4		
PT5215	143T-286T	20 - 24	22.9	26.6	23.9	27.6	24.7	28.4	25.7	29.4	26.4	30.1				
PT5215	143T-326T	20 - 24	22.9	26.6	23.9	27.6	24.7	28.4	25.7	29.4	26.4	30.1	27.1	31.2		
PT6307	143T-326T	24	23.2	27.0	24.2	27.9	24.9	28.7	25.9	29.7	26.7	30.5	27.6	31.4		
PT7315	143T-365T	24	27.3	31.1	28.3	32.1	29.1	32.9	30.1	33.9	30.8	34.7	31.8	35.6	32.7	36.6
PT8407	143T-365T	NA	22.0	26.5	23.0	27.5	23.8	28.3	24.8	29.3	25.5	30.0	26.5	31.0	27.5	32.0



Shaft Mount	Weight (lbs.)	E										
		A	B	C	D	Min	Max	F	G	H	J	K
PT1107	49	14.63	11.00	13.50	9.25	17.1	21.3	1.59	12.00	3.38	5/8x7	3.88
PT2115	50	14.63	11.00	13.50	9.25	18.6	22.8	1.59	12.00	3.38	5/8x7	4.18
PT3203	51	14.63	11.00	13.50	9.25	19.8	24.0	1.59	12.00	4.25	5/8x8	4.88
PT3203	93	18.63	17.00	17.50	14.25	20.0	24.2	1.78	15.50	4.25	3/4x8	4.88
PT4207	113	18.63	17.00	17.50	14.25	21.3	26.1	1.78	15.50	4.63	3/4x8	6.13
PT4207	129	20.50	18.50	19.25	16.50	21.3	26.1	1.84	17.50	4.63	3/4x8	6.13
PT5215	113	18.63	17.00	17.50	14.25	21.3	26.1	1.78	15.50	4.13	3/4x8	6.65
PT5215	140	20.50	18.50	19.25	16.50	21.3	26.1	1.84	17.50	4.13	3/4x8	6.65
PT6307	143	20.50	18.50	19.25	16.50	22.7	27.4	1.84	17.50	4.50	3/4x8	7.31
PT7315	172	22.50	19.00	21.25	16.50	23.5	27.7	2.50	19.25	4.75	1x9	7.81
PT8407	172	22.50	19.00	21.25	16.50	24.3	28.8	2.50	19.25	4.75	1x9	7.81

G22 POWER TORQUE® Accessories

BELT GUARDS



All-Steel construction

Adjustable to fit a wide range of sheaves and motor frames

Designed for easy installation, no drilling required

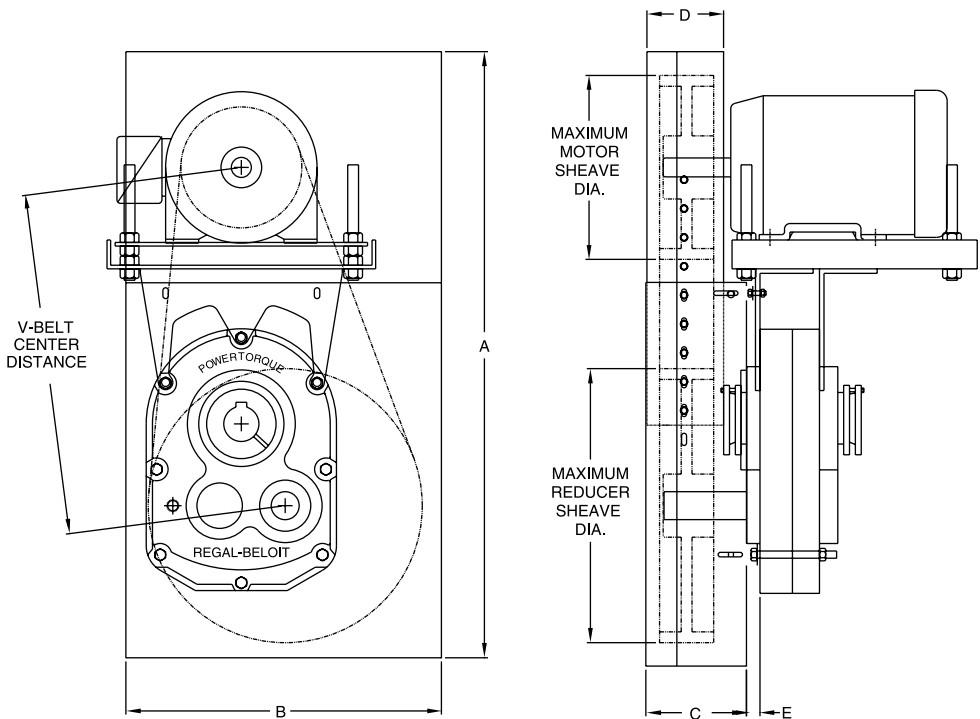

VERTICAL BELT GUARDS

Shaft Mount Model	NEMA Motor Frame	Weight (lbs.)	V-Belt Center Distance		Maximum Sheave Dia.		A		B	C	D	E
			Min	Max	Motor	Reducer	MIN.	MAX.				
PT1107	56C-215T	51	17.6	22.7	6.4	18.0	31.75	39.75	22.00	5.40	4.31	0.56
PT2115	56C-215T	54	18.7	23.9	8.6	19.0	32.75	40.75	22.00	5.40	4.31	0.56
PT3203	56C-286T	57	20.2	27.2	8.6	19.0	35.75	43.75	22.00	5.40	4.31	0.56
PT4207	143T-326T	71	21.2	29.8	12.0	19.0	40.25	48.25	23.50	6.90	5.31	0.63
PT5215	143T-326T	75	22.7	31.2	12.0	19.0	41.75	49.75	23.50	6.90	5.31	0.63
PT6307	143T-326T	104	25.9	34.2	14.0	25.0	48.25	56.25	29.25	8.70	7.44	2.00
PT7315	143T-365T	126	30.6	39.9	14.0	30.0	55.25	63.25	34.25	8.70	7.44	1.25
PT8407	143T365T	126	31.9	41.2	14.0	30.0	55.25	63.25	34.25	8.70	7.44	1.25

VERTICAL LONG BELT GUARDS

Shaft Mount Model	NEMA Motor Frame	Weight (lbs.)	V-Belt Center Distance		Maximum Sheave Dia.		A		B	C	D	E
			Min	Max	Motor	Reducer	MIN.	MAX.				
PT1107	56C-215T	55	20.6	25.7	6.4	18.0	34.50	42.50	22.00	5.40	4.31	0.56
PT2115	56C-215T	57	21.7	26.9	8.6	19.0	35.50	43.50	22.00	5.40	4.31	0.56
PT3203	56C-286T	60	23.2	30.2	8.6	19.0	38.75	46.75	22.00	5.40	4.31	0.56
PT4207	143T-326T	82	25.7	34.3	12.0	19.0	44.50	52.50	23.50	6.90	5.31	0.63
PT5215	143T-326T	80	29.5	37.9	12.0	19.0	48.00	56.00	23.50	6.90	5.31	0.63
PT6307	143T-326T	123	39.9	48.2	14.0	25.0	62.25	70.25	29.25	8.70	7.44	2.00
PT7315	143T-365T	150	45.6	54.9	14.0	30.0	71.00	79.00	34.25	8.70	7.44	1.25
PT8407	143T-364T	150	44.9	54.3	14.0	30.0	71.00	79.00	34.25	8.70	7.44	1.25

BELT GUARDS

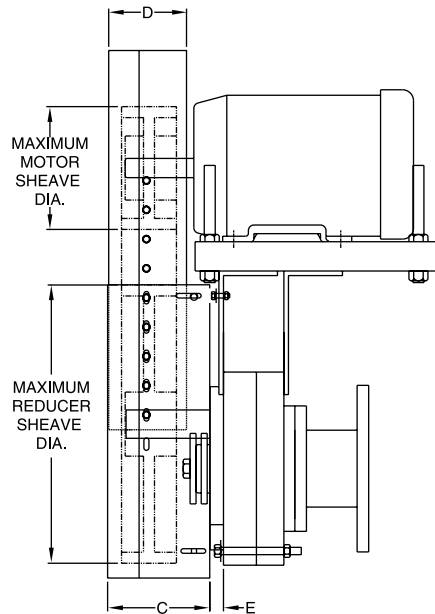
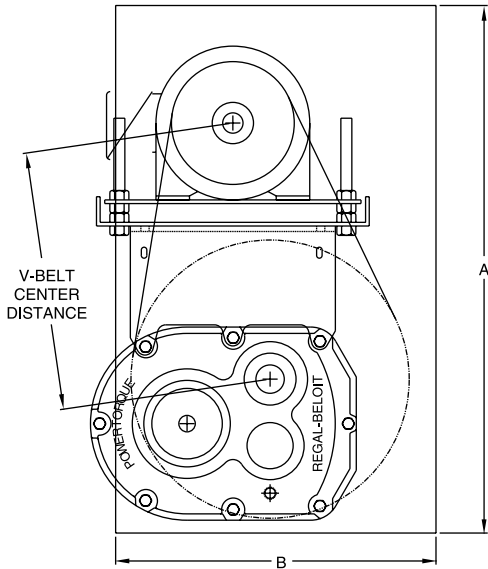

All-Steel construction
Adjustable to fit a wide range of sheaves and motor frames
Designed for easy installation, no drilling required

HORIZONTAL BELT GUARDS

Shaft Mount Model	NEMA Motor Frame	Weight (lbs.)	V-Belt Center Distance		Maximum Sheave Dia.		A		B	C	D	E
			Min	Max	Motor	Reducer	MIN.	MAX.				
PT1107	56C-215T	48	13.5	19.0	6.4	18.0	27.75	35.75	22.00	5.40	4.31	0.56
PT2115	56C-215T	51	14.9	20.0	8.6	19.0	28.75	36.75	22.00	5.40	4.31	0.56
PT3203	56C-286T	53	15.8	22.9	8.6	19.0	31.50	39.50	22.00	5.40	4.31	0.56
PT4207	143T-326T	67	16.9	25.4	12.0	19.0	36.25	44.25	23.50	6.90	5.31	0.63
PT5215	143T-326T	64	16.6	25.2	12.0	19.0	35.75	43.75	23.50	6.90	5.31	0.63
PT6307	143T-326T	92	17.0	25.5	14.0	25.0	39.50	47.50	29.25	8.70	7.44	2.00
PT7315	143T-365T	105	22.1	31.0	14.0	30.0	41.75	49.75	34.25	8.70	7.44	1.25
PT8407	143T-365T	105	16.1	25.4	14.0	30.0	41.75	49.75	34.25	8.70	7.44	1.25



HORIZONTAL LONG BELT GUARDS

Shaft Mount Model	NEMA Motor Frame	Weight (lbs.)	V-Belt Center Distance		Maximum Sheave Dia.		A		B	C	D	E
			Min	Max	Motor	Reducer	MIN.	MAX.				
PT1107	56C-215T	53	19.5	24.7	6.4	18.0	33.75	41.75	22.00	5.40	4.31	0.56
PT2115	56C-215T	56	20.9	26.0	8.6	19.0	34.75	42.75	22.00	5.40	4.31	0.56
PT3203	56C-286T	59	21.8	28.9	8.6	19.0	37.25	45.25	22.00	5.40	4.31	0.56
PT4207	143T-326T	73	23.2	31.4	12.0	19.0	41.50	49.50	23.50	6.90	5.31	0.63
PT5215	143T-326T	73	22.9	31.2	12.0	19.0	42.00	50.00	23.50	6.90	5.31	0.63
PT6307	143T-326T	100	23.2	31.4	14.0	25.0	45.50	53.50	29.25	8.70	7.44	2.00
PT7315	143T-365T	115	27.3	36.6	14.0	30.0	48.00	56.00	34.25	8.70	7.44	1.25
PT8407	143T-365T	115	22.0	31.4	14.0	30.0	48.0	56.00	34.25	8.70	7.44	1.25

COOLING FANS

Available upon request, consult factory for details

